

Assembly Instructions

KarateKickMaster

KarateKickMaster STATEMENT OF WARRANTY

The structural components of Motion Master Corporation (MMC) KarateKickMaster stretching machines are warranted to the original owner to be free from defects in material and workmanship under normal use for a period of two (2) years from date of delivery. MMC will replace those parts returned to MMC, which prove to be defective for the full two (2) year warranty period.

The KarateKickMaster pad's vinyl covering is warranted to the original owner to be free from defects in material and workmanship under normal use for a period of six (6) months from date of delivery. MMC will replace those vinyl coverings returned to MMC, which prove to be defective for the full six (6) month period.



HERE'S WHAT YOU GET. From L-R: Short leg, Long leg, Actuator, Pad, 4 - 9/16 bolts, washers, nuts & 1 - 3/4" bolt, washer, and nut. Forked arm, Upright with pin. Note: The actuator is shipped inserted into the upright and is coated with a lubricant. Shipping weight is 69 pounds.



HERE'S WHAT YOU NEED. From L-R: Locking wrench, 9/16" wrench, 3/4" wrench

HERE'S HOW YOU PUT IT TOGETHER.

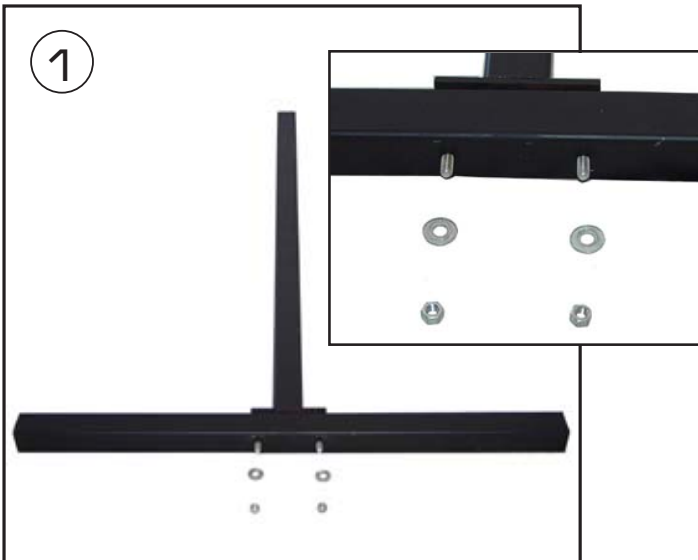

1. Bolt long leg and short leg together with two 9/16" bolts, flat washer and nuts.

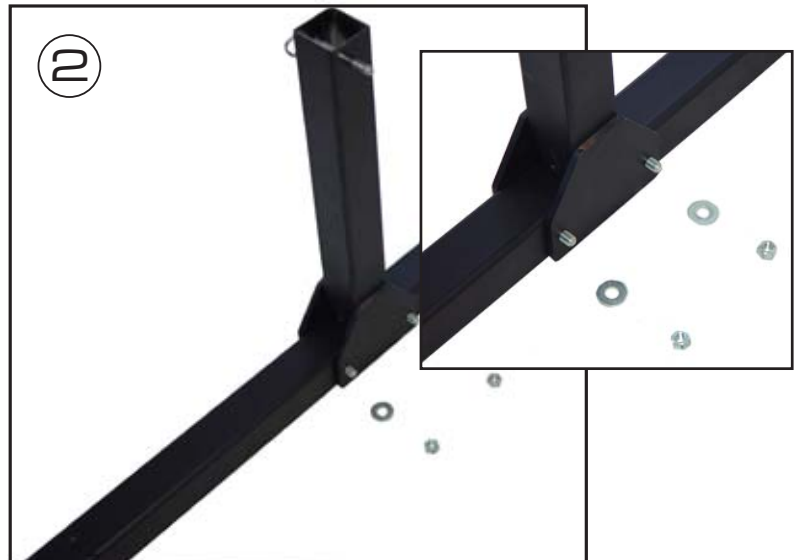

2. Bolt upright to long leg with two 9/16" bolts, flat washers and nuts

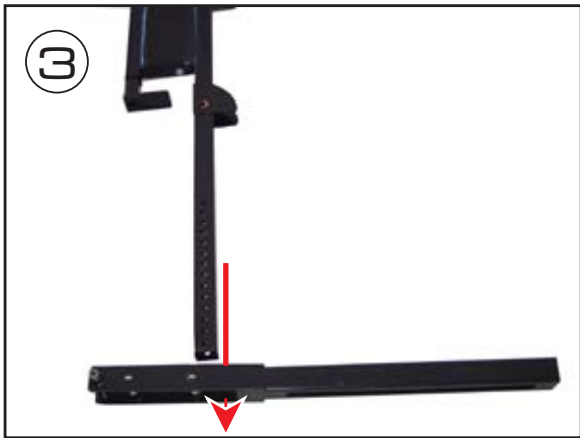

3. Line up holes in actuator post and forked arm. Bolt together with 3/4" bolt, flat washer, and nut. NOTE: This is a tight fit. You may need to spread the forks to line up the holes. Do not over tighten; make sure the forked arm pivots freely.



4. Insert actuator post into the upright and pin using any hole. This is easier with a helper. You will adjust the height later.



5. Insert pad post down through slot on forked arm. Secure with the tightening handle.



6. Your Karate Kickmaster is fully assembled.